

# BUTTER & MARGARINE

DOSING AND PACKAGING SOLUTIONS



## Table of contents

BUTTER & MARGARINE SOLUTIONS	4
LINE STEPS	5
FB SERIES DOSING AND WRAPPING	6
MULTIPACK 2000/3000 LOW SPEED DOSING AND WRAPPING	8
MULTIPACK 5500 MEDIUM SPEED DOSING AND WRAPPING	10
MULTIPACK 7000 HIGH SPEED DOSING AND WRAPPING	12
MULTIPACK 8000/8600 HIGH SPEED DOSING AND WRAPPING	14
ECOPACK SERIES MOULDING AND WRAPPING	16
COPPARAPID FILLING AND SEALING	18
CARTOMAT 8400 CARTONING	20
AB8 CARTONING	22
END OF LINE SOLUTIONS	24
IMA IN THE BUTTER & MARGARINE MARKET	27

AS A WORLD LEADER IN THE FIELD OF PACKAGING MACHINERY, IMA HAS MORE THAN 100 YEARS OF EXPERIENCE IN PACKAGING BUTTER AND MARGARINE. COVERING ALL ASPECTS OF THE PACKAGING PROCESS, IMA PROVIDES EQUIPMENT FOR DOSING, WRAPPING, FILLING, SEALING, CARTONING AND END-OF-LINE.

Considering the extent of requirements in the butter and margarine sector, and thanks to decades of specific experience, IMA acts as a key technological partner and business advisor in all areas of butter and margarine packaging. Alongside the world's most comprehensive range of packaging equipment for butter and margarine, tailor-made solutions are developed to respond to the markets fast evolving needs.

Broad knowledge gained globally enables IMA specialists to optimize customer's investments and ensure ongoing assistance and technological developments to maintain their competitive advantage.

## DOSING AND WRAPPING



## FILLING AND SEALING



## CARTONING



### MINI PORTIONS

Mini-portions are the most hygienic way to package portions for use in hotels, on airplanes, for catering purposes and for single-person households without compromising quality and freshness.



### CONSUMER PORTIONS

Most consumers prefer to buy butter and margarine in consumer portion. This makes the products easy to use for them.



### BIG PORTIONS

Butter and margarine in big portions can be wrapped or packed in pre-formed tubs.

# FB SERIES DOSING AND WRAPPING

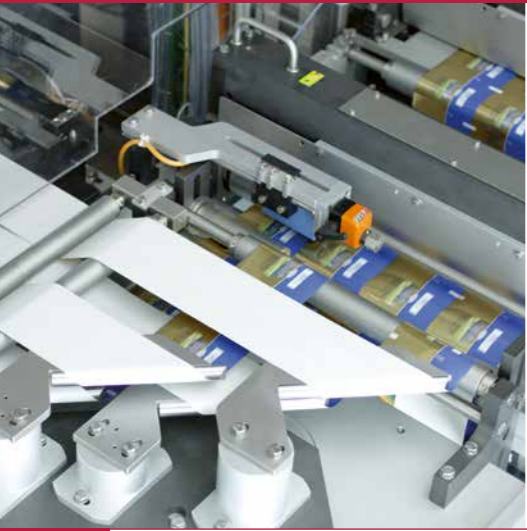

Foil feeding



Shell forming



Dosing unit

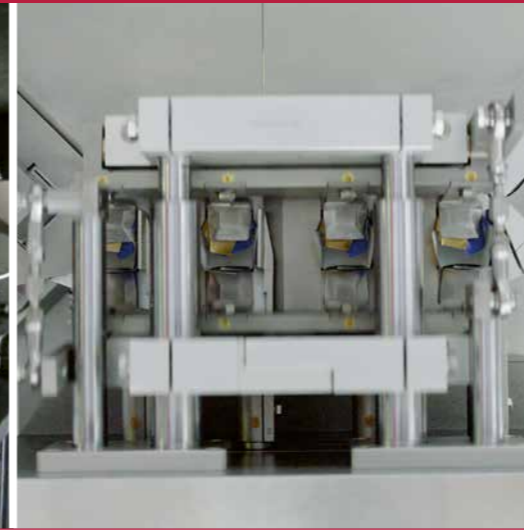

Folding unit

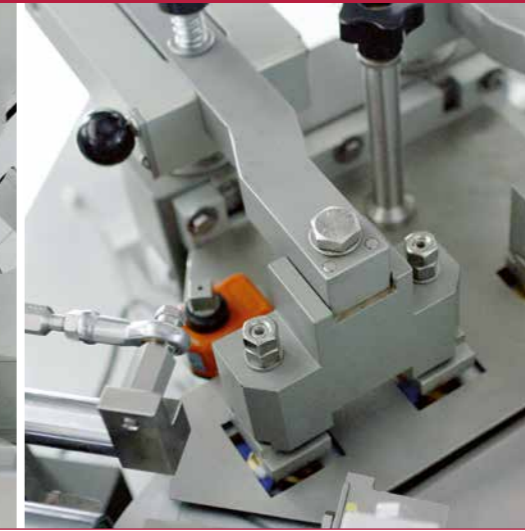

Pressing unit



Product outfeed

## BUTTER DOSING AND WRAPPING TAILORED TO YOUR NEEDS

The FB Series of dosing and wrapping machine for butter in square and rectangular portions, provides the optimum packaging solution at high or low speeds. Compact in size, each version ensures efficient performance and a top quality fold.

The FB Series is developed to suit the customer's specific requirements in terms of processing speeds.

For customers requiring high-speed processing, the FB8 handles 800 ppm ranging from 7 to 20g. Thanks to a compact footprint, user-friendly HMI and a design which allows easy, quick changeover of the portion base size, the FB8 is the ideal choice for dairies wanting optimum productivity and efficiency.

The FB220 is a low-speed fully mechanical machine, offering a production capacity of up to 280 ppm of 7 to 25g wrapped portions.

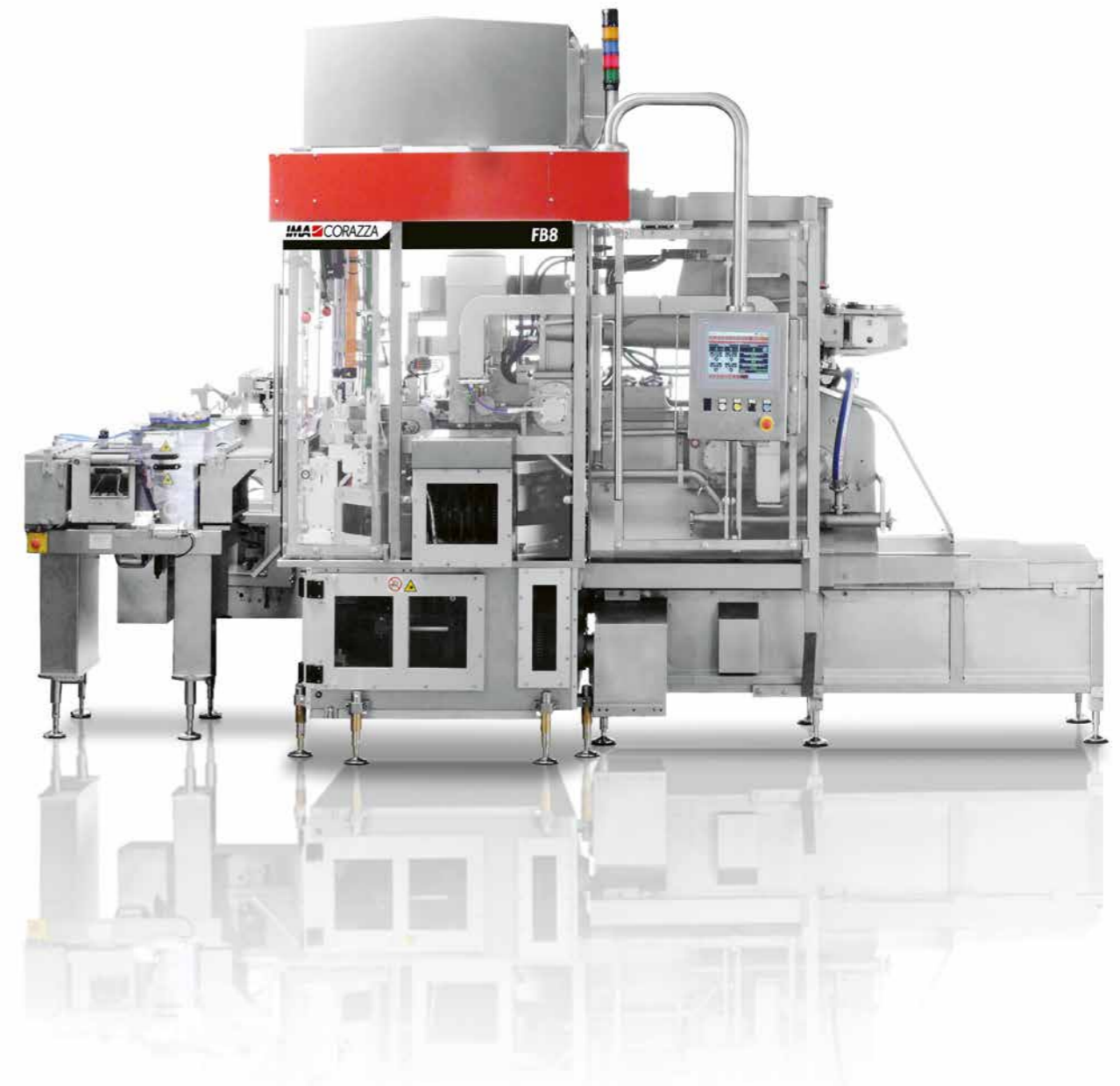

# MULTIPACK 2000/3000 LOW SPEED DOSING AND WRAPPING



Unwinding unit

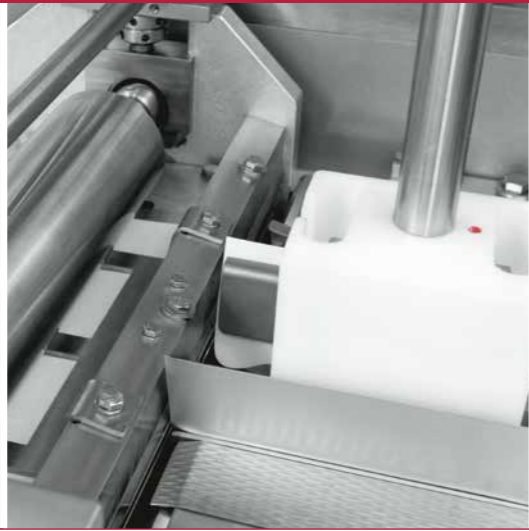

Folding box



Dosing unit

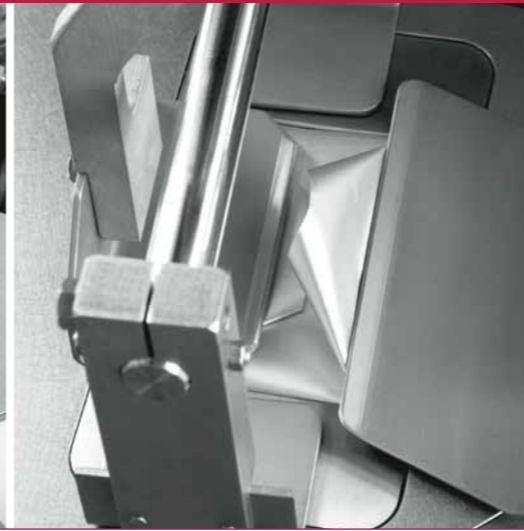

End folding unit



Calibration unit

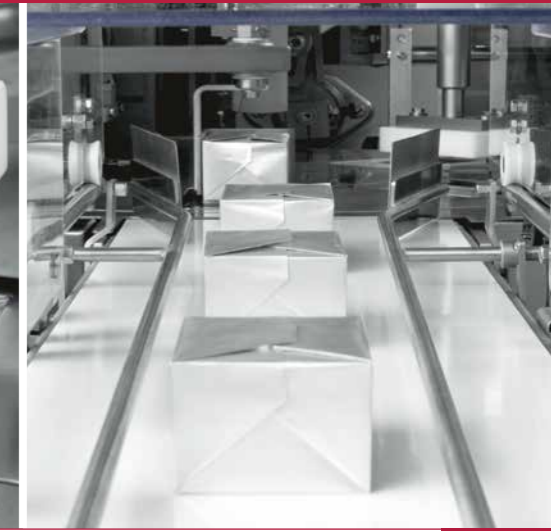

Product outfeed

## MULTIPACK 2000: HIGH QUALITY AT AN ECONOMICAL LEVEL

Compactness and flexibility describe the MULTIPACK 2000. With a dosing variety from 50 up to 500 g and an output of 100 ppm, this dosing and wrapping machine stands for high quality at an economical level.

The MULTIPACK 2000 accomplishes a supreme dosing accuracy ( $s=0.5$  g for  $Q_n \leq 250$  g). Further highlights are the servo-drive technology and the remarkable reliability of the machine.

## MULTIPACK 3000: THE MOST FLEXIBLE IN THE WORLD WITH ULTIMATE OPERATING CONVENIENCE

The single-cell MULTIPACK 3000 offers the highest flexibility worldwide for wrapping pasty products. Typical of other IMA Benhil dosing and wrapping machines, it ensures exceptional dosing accuracy ( $s=0.3$  g for  $Q_n < 250$  g), excellent reliability and a long service life.

The MULTIPACK 3000 wrapping machine covers an extraordinary range of dosing weights between 50 and 1000 g of pasty type products, packing up to 100 ppm.

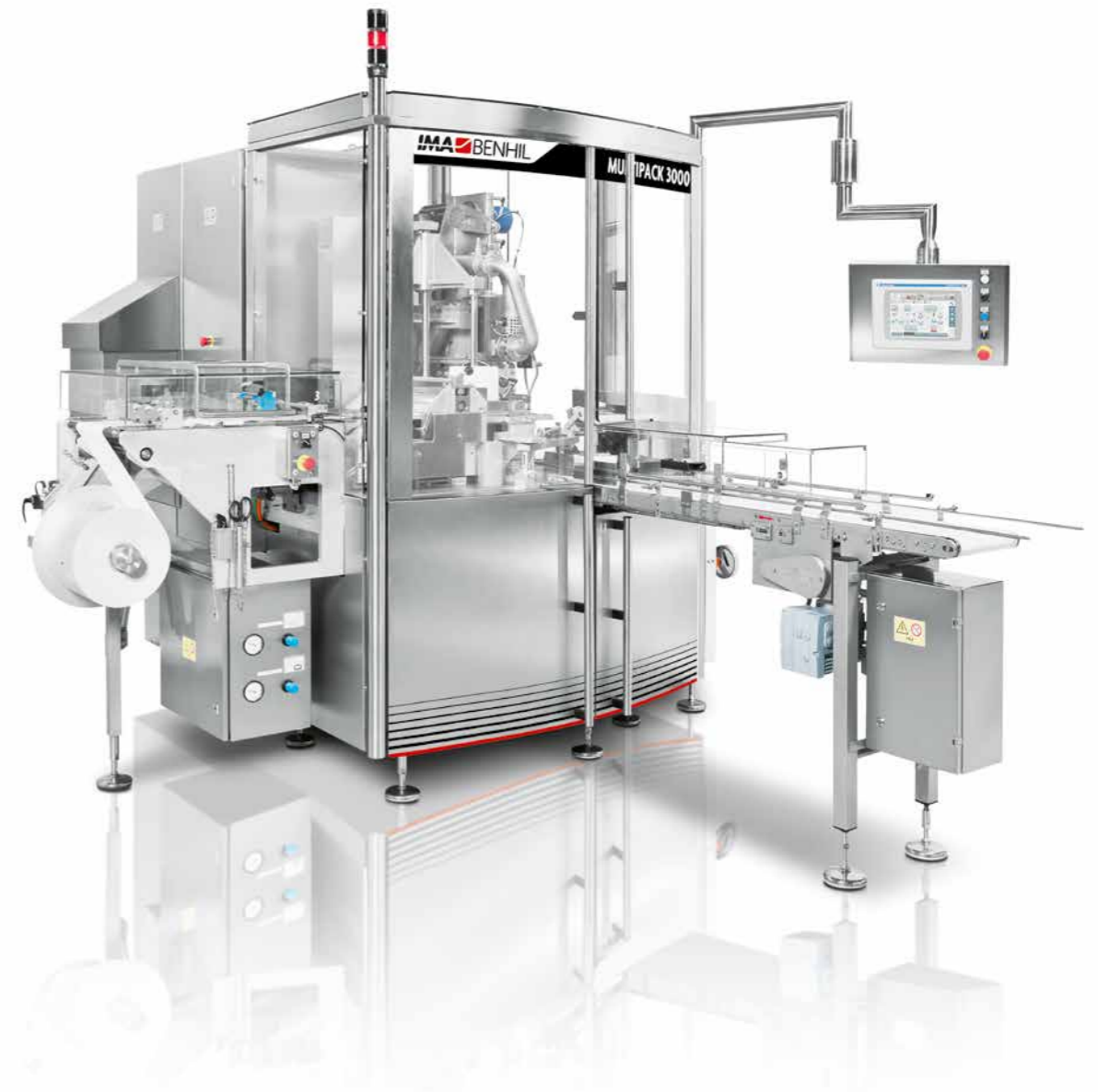

# MULTIPACK 5500 MEDIUM SPEED DOSING AND WRAPPING

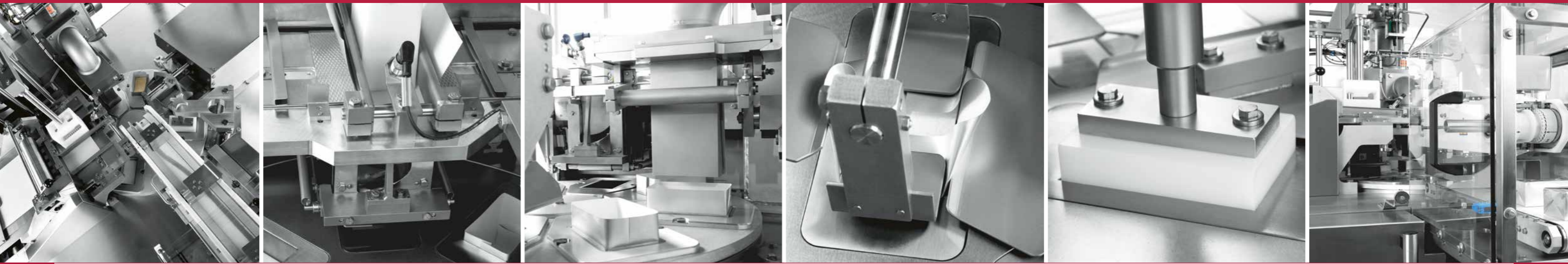

Production area

Folding box

Dosing unit

End folding unit

Calibration unit

Product outfeed

## THE SERVO-DRIVEN BENCHMARK FOR DOSING AND WRAPPING PASTY PRODUCTS

The MULTIPACK 5500 features a servo-driven dosing device and servo-driven lifting cells, boosting operating speeds to make it the world's top-performing, energy-efficient single-cell filling and wrapping machine for pasty products.

Flexible and energy-efficient thanks to its servo-driven concept, the MULTIPACK 5500 wrapping machine reduces power consumption by up to 30% and offers a range of dosing weights between 50 and 500 g of pasty type products, packing up to 140 ppm.

Boasting exceptional dosing accuracy ( $s=0.3$  g for  $Q_n < 250$  g), this machine can be fitted with a CIP cleanable dosing system which fulfils industry standard hygienic requirements.



## CARTOMAT 8400

Cartomat 8400 is the ideal cartoner to be combined with our one lane Multipack series model for medium output. Having its separate drive, it can be also combined with others dosing and wrapping machines.



# MULTIPACK 7000 HIGH SPEED DOSING AND WRAPPING



Advanced wrapping system

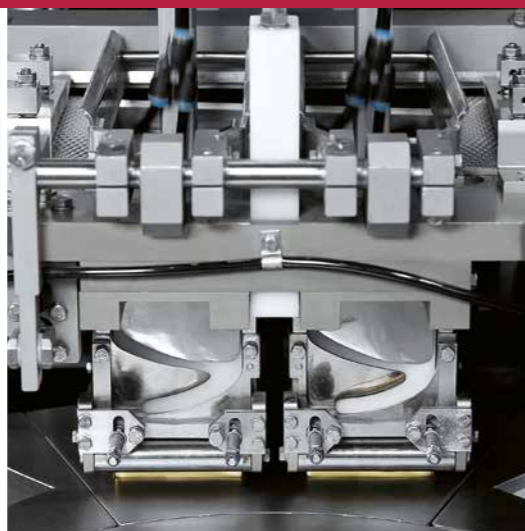

Folding boxes

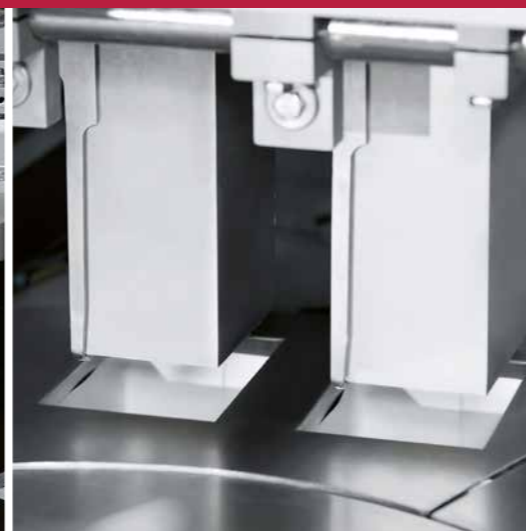

Dosing unit



Folding unit



Calibration unit



Discharge unit

## MULTIPACK 7000: HIGH-SPEED, TOP-VALUE MACHINE

With an output of up to 200 packets per minute and a filling weight and size range of 50 to 250g, the new double-cell Multipack 7000 completes the output range for the Multipack series and further expands our equipment portfolio. Bridging the gap between the medium and high-speed range, the Multipack 7000 combines performance and efficiency to provide a valid solution at an affordable price.

The combination between size flexibility, within the mentioned dosing range, and the high speed that can be achieved by the machine guarantees excellent performance and perfectly shaped packets.

The Multipack 7000 is outstanding for its modern, attractive design, for the integrated cip cleanable dosing system which fulfils industry-standard hygienic requirements, and the intelligent control technology.

The Multipack 7000 boasts exceptional filling accuracy ( $s = 0.3 \text{ g}$  for  $Q_n < 250 \text{ g}$ ), extremely high reliability, and state-of-the-art technology.



# MULTIPACK 8000/8600 HIGH SPEED DOSING AND WRAPPING



Wrapper feeding system

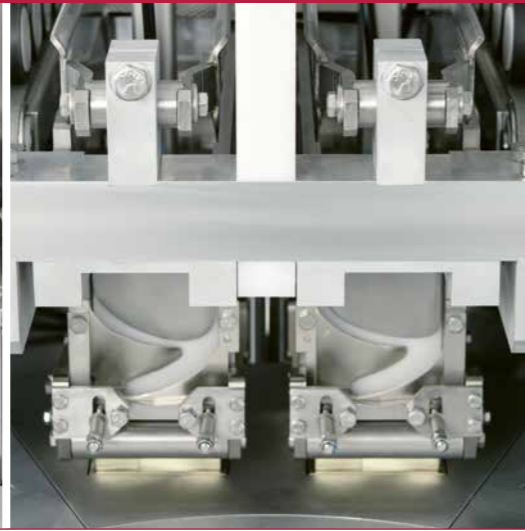

Folding box

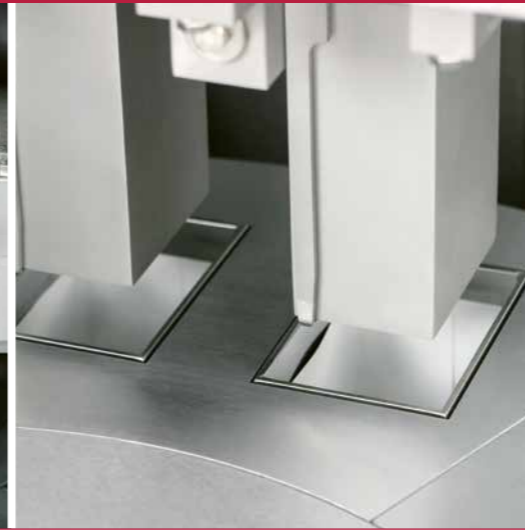

Dosing unit



End folding unit

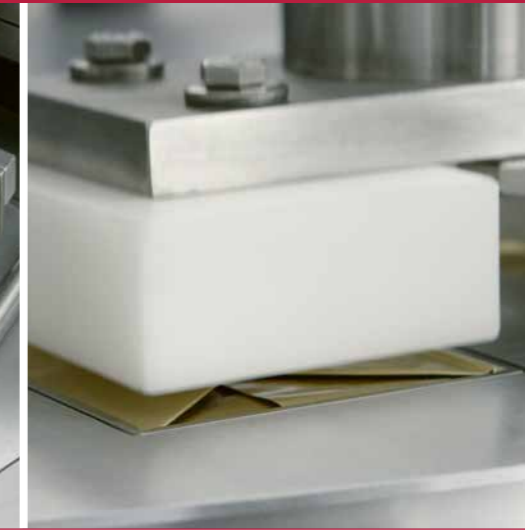

Calibration unit



Product outfeed

## MULTIPACK 8000: THE ADVANCED MODULAR SOLUTION

MULTIPACK 8000, double-cell machine for dosing and wrapping pasty products, implements state-of-the-art technology for maximum efficiency and optimum results.

Unique for such a high-speed machine, the MULTIPACK 8000 wrapping machine offers the flexibility of a dosing range between 100 and 500 g at a nominal output of 250 ppm and ensures incredible dosing accuracy ( $s=0.3$  g for  $Q_n < 250$  g), extremely high reliability and sound construction.

## MULTIPACK 8600: ATTRACTIVE, INTELLIGENT AND OFFERING OUTSTANDING CONTROL TECHNOLOGY FOR THE HIGHEST OUTPUT WORLDWIDE

With an output of up to 300 ppm and a size range of 50 to 180 g, the double-cell MULTIPACK 8600 achieves the highest output worldwide, for dosing and wrapping pasty type products, proving exceptional size flexibility for such high-speed operation.

Furthermore it is equipped with an advanced dosing system with constant dosing time for different filling profiles ensuring outstanding dosing accuracy ( $s=0.3$  g for  $Q_n < 180$  g).



## CARTOMAT 8562/8563

The MULTIPACK 8600 can work in line with the CARTOMAT 8562/8563, which is a fully automatic wrap-around cartoner for consumer portions with carton closing by hot melt (inserted flaps or gluing all around types). Starting from flat blank cartons and with an output up to 100 cartons per minute it can handle 2-24 portions allowing different products configurations: e.g. from 2x1 in one layer up to 6x2 in two layers.





# ECOPACK SERIES MOULDING AND WRAPPING

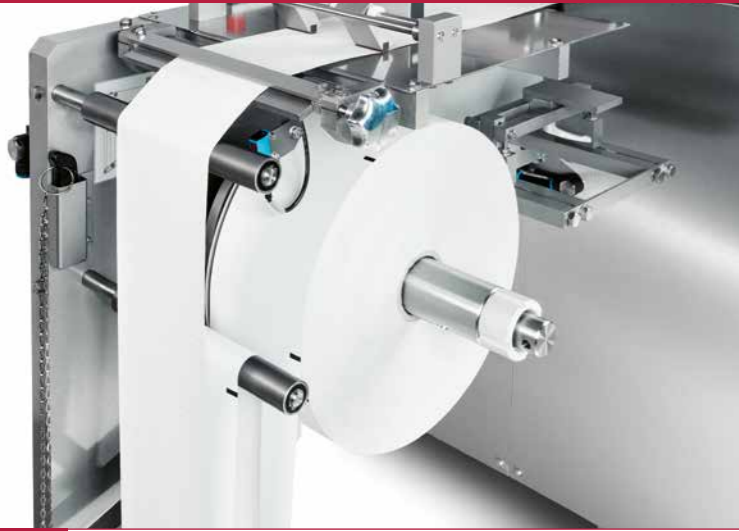

Advanced wrapping system

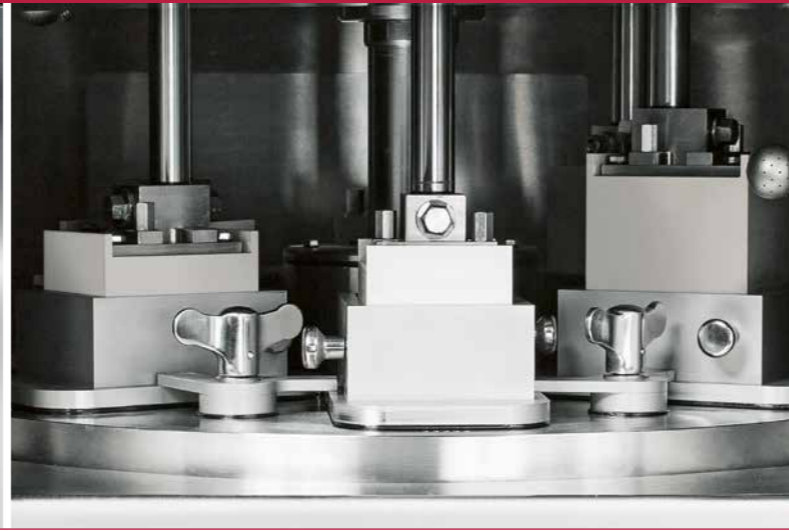

Dosing unit



Wrapping wheel



Packet outfeed

## ECONOMICAL WRAPPING WITH EXTREMELY GENTLE PRODUCT HANDLING

Ideal for pasty products, the ECOPACK F1000/1500 is a fully automatic moulding and wrapping machine performing end-side folding, and ensuring extremely gentle product handling, low wrapping material consumption and excellent dosing accuracy ( $s=0.4$  g for  $Q_n=100$  g). With dosing weights ranging between 100 and 500 g and a nominal output of 125/150 ppm, the ECOPACK F1000/1500 wrapping machine is flexible and provides accurate dosing and reduces wrapping material consumption by up to 30% compared to traditional folding styles.



## CARTOMAT 8554

The CARTOMAT 8554 is a fully automatic wrap-around cartoner with carton closing by cold glue or hot melt (inserted flaps or gluing all around types). Starting from flat blank cartons and with an output up to 250 cartons per minute, it allows many product configurations by handling 2-24 portions: from 2x1 in one layer up to 8x2 in one layer, or 4x3 in two layers. The CARTOMAT 8554 is suitable for working in line with small portions machine MULTIPACK 8358 as well as with the ECOPACK and other MULTIPACK machines.



# COPPARAPID FILLING AND SEALING



Cup dispense

Main filling unit

Sealing unit

Standard filling unit

Filling unit detail

Sealing unit

## COPPARAPID 4000: LATEST DEVELOPMENT FOR THE FILLING AND SEALING MACHINE

The COPPARAPID 4000 provides you with the latest technology for filling of pasty products into different sizes of pre-formed cups.

Thanks to a single platform utilising as many standard components as possible, it is possible to cover a large range of container profiles and shapes.

The machine is able to accommodate products by direct feed, compensator, or can be installed with a hopper for products with alternative characteristics.

Quick and easy changeover for format parts combined with the recipe functionality achieved with the use of integrated servo technology has minimized downtime between product and packaging changeovers.



## COPPARAPID 6000: TUB FILLING AND SEALING MACHINE

The tub filling and sealing machine COPPARAPID 6000 is designed to fill pasty products with high hygiene requirements into preformed tubs. This four line machine enables an output of up to 200 tubs per minute.

Make your choice between filling weights within the wide dosing range of 50 to 1000 g, various dosing systems for different product requirements and retrofitting of complete functional modules. The COPPARAPID 6000 is outstanding for its modular concept, extremely high reliability and compactness, as well as for exceptional filling accuracy ( $s=0.5$  g for  $Q_n < 250$  g).



# CARTOMAT 8400 CARTONING

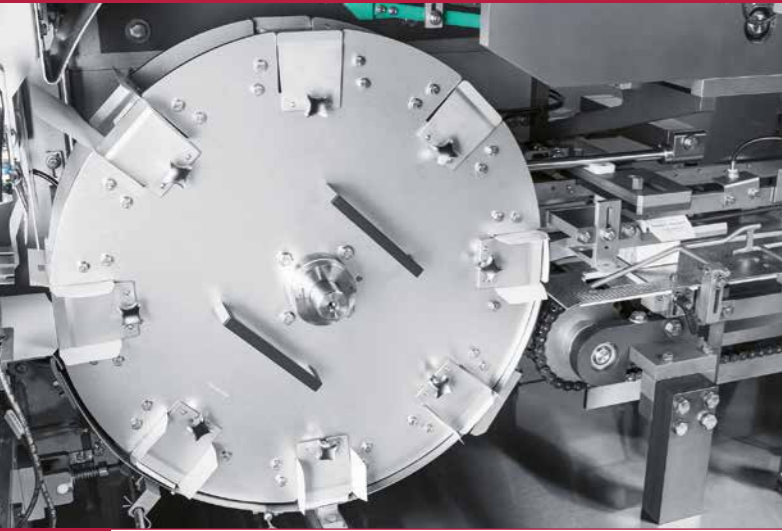

Folding wheel



Product stacking



Carton closing



Product outfeed

## CARTOMAT 8400 FLEXIBLE, TOP-VALUE MACHINE, OUTSTAND FOR ITS MODERN, ATTRACTIVE DESIGN.

CARTOMAT 8400 is a fully automatic wraparound cartoner designed to pack butter, margarine and spreads in sticks and bricks.

Starting from flat blank cartons, and with an output up to 50 cartons per minute, it handles between 2 and 12 portions. Extremely versatile in terms of the possible portion configurations, which can be arranged in single or double layers, CARTOMAT 8400 is also well-suited to managing long size cartons and enables extremely fast and easy format changes for both brick and carton specifications.

CARTOMAT 8400 is the ideal cartoner to implement in line with our one-lane Multipack series model for medium output. Having its own separate drive, it can be also combined with other dosing and wrapping machines.

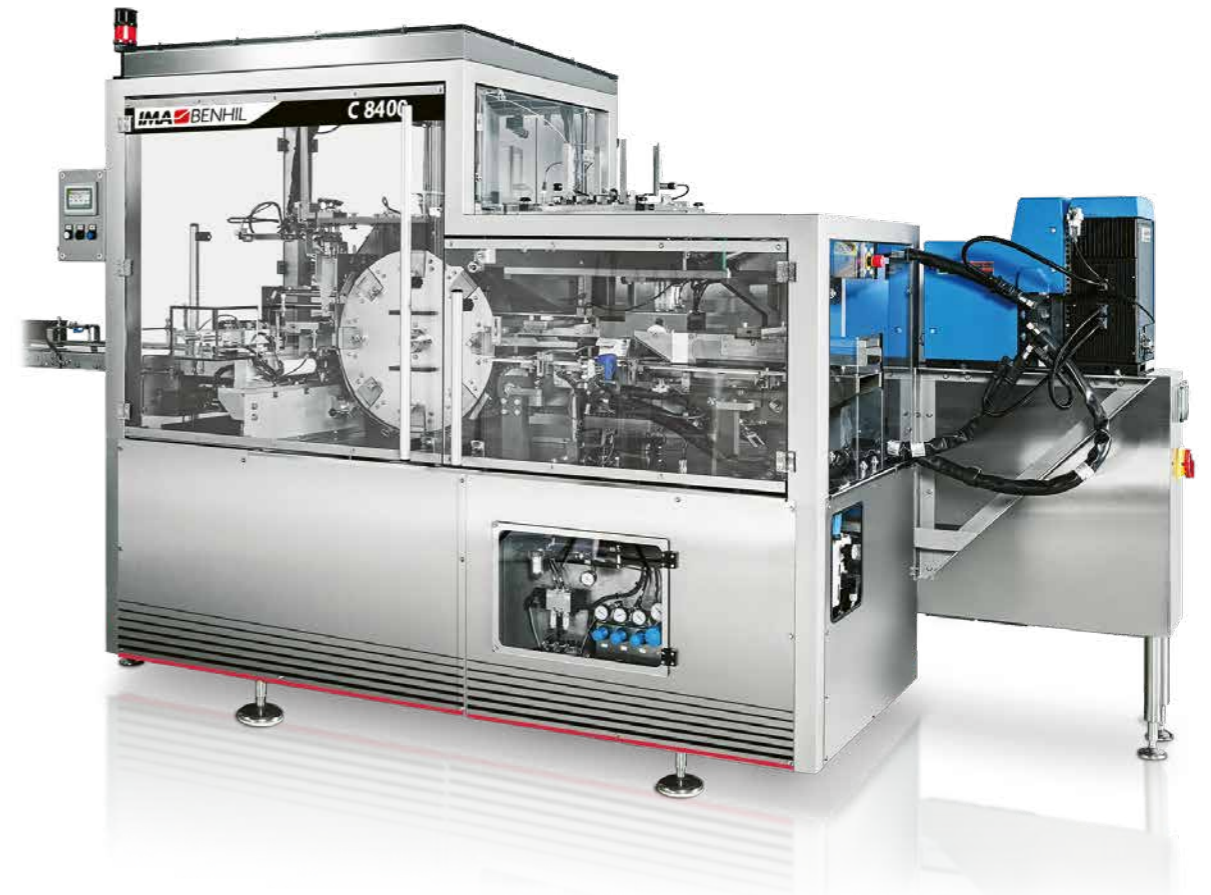

# AB8 CARTONING



Grouping and layering



Box filling and wrapping



Box blank denesting



Side glueing and closing



Pressing unit

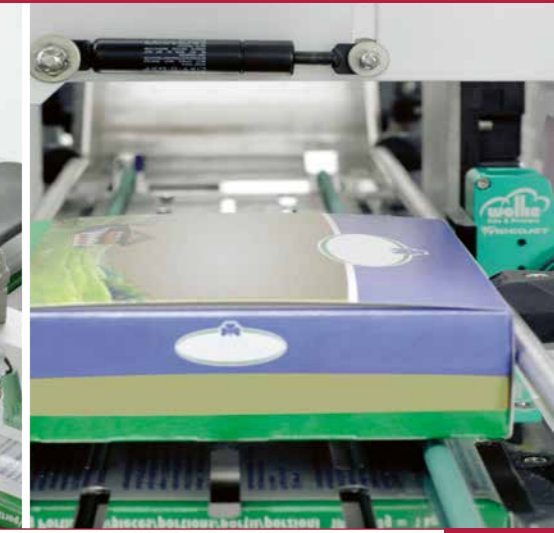

Box outfeed

## BUTTER, MARGARINE AND YEAST, BUNDLED AND BOXED

The AB8 is a wrap-around solution for boxing butter or yeast, drawing on flat blanks, which are sealed using hot-melt glue on the end flaps. Processing stacked bundles received on the indexing table, the AB8 wraps a flat blank around the formed bundle, closes and seals the carton before capsizing it 180° so that portions are face-up. The AB8 can process up to 80 boxes/min.

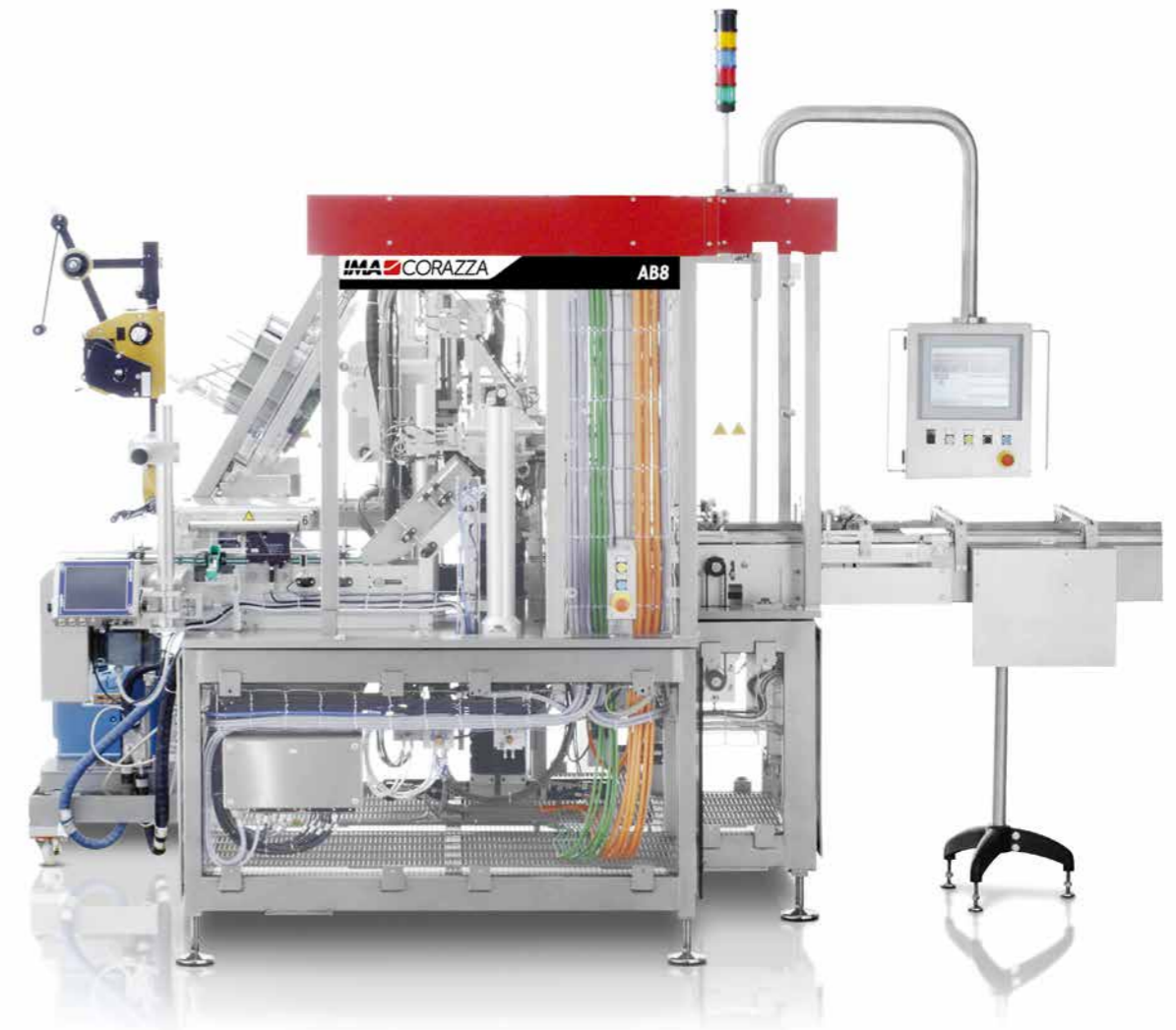

# END OF LINE SOLUTIONS

## IMA HAS A LONG TRADITION OF DESIGNING AND MANUFACTURING END-OF-LINE MACHINES.

The machines and feeder units are extremely flexible, enabling the processing of countless types of product and package. The constant flow of ideas generated by our close-knit team has resulted in a number of innovative concepts such as machines with a small footprint, integrated packaging solutions, rapid size changeover and the handling of complex or non-standard products. The machines feature a robust balcony structure and are designed with the operator in mind. Simple to use and easily accessible, they guarantee maximum protection for both operator and product, at every stage of production. The number of size parts is kept to a minimum and size changeover is tool-free.



### OVERWRAPPING

Our machines have specific film film-winding, cutting and sealing systems to ensure that the film is always cut with a geometrically precise fold and sealed without wrinkles, air bubbles or other imperfections. The flexibility of these machines enables transverse sealing underneath the bundle or lateral sealing. Our wide range of wrapping machines can process any type of pack, film or paper, even on products with irregular shapes.

- AF60
- A50 / A100
- 3701 / 11 / 21
- 3705
- HYWRAP 20



### SHRINK WRAPPING & STRETCH BANDING

We offer a range of machines that can cover different speeds, with dedicated solutions for products whose shape tends to vary widely. The machines can always be combined with a heat-shrink tunnel with lower power consumption.

- MS260
- MS560 - T600



### SIDE AND TOP LOADING CASE PACKING

A very wide range of side and top loading case / packing machines is available to handle all types of products. For each specific market application and speed, we provide the best solution to get the product into the final corrugated cardboard case in the most efficient way. Our case packers can be integrated with palletizing solutions in a compact structure and with a very simple pallet management.

- CPH2
- CP18 / 28 / 38 / 48 / 50
- CPV15 / 20
- 3754

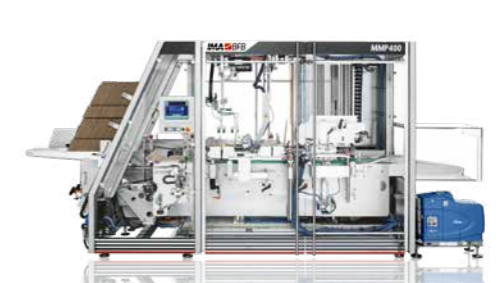

### WRAP AROUND CASE PACKING

The new wrap around case packer is built to pack individual or bundled product into cases, display boxes or trays starting from flat-blanks. This machine has been developed in response to new market requirements such as the cantilever design of its structure, which ensures complete accessibility and easy cleaning. In addition, great importance has been given to the ergonomic position of all its components, like the flat-blanks magazine positioned to allow easy case loading.

- MMP400 / 600



## PALLETIZING AND DEPALLETIZING

Available in several versions ranging from basic applications up to more sophisticated solutions, IMA BFB palletizers have a solid structure and use precise, rapid multi-axis robotized systems for accurate positioning of products on pallets.

Our offer includes integrated case-packing and palletizing solutions in a compact structure and with an extremely simple pallet management.

- RP Palletizing modules
- RD Depalletizing / Palletizing modules

## FEEDING AND MANIPULATION

IMA is able to provide customized robotic handling, assembly and feeding systems for shaped containers or unstable products. IMA offers flexible and modular technological solutions to set up a complex assembly line and to transfer products between assembly modules.

- T-LOAD

## BENHIL

### MARKET LEADER FOR BUTTER AND MARGARINE WRAPPING

Benhil offers filling and wrapping machines for butter and margarine in consumer or big portions as well as tub filling machines.

Over 100 years of experience and an installed base of more than 2,000 machines worldwide makes Benhil a trustworthy partner whose understanding of the market is a priceless asset.

Benhil offers dosing and wrapping machines for consumer packs and big portions, with an output ranging from 6,000 – 30,000 packets/h, as well as cup and tub filling machines.

Benhil also supplies secondary packaging solutions including wrap-around cartoners for display cartons and semi-automatic collecting and stacking machines.

## CORAZZA

### THE LEADING MANUFACTURER OF PACKAGING MACHINES FOR DAIRY AND CONVENIENCE FOOD

Corazza is the world's leading name for dairy and convenience food packaging equipment, offering complete packaging lines for fresh, processed & cream cheese, butter, yeast, paste & pressed bouillon cube.

With an installed base of more than 4,500 machines worldwide Corazza is the world's leading name for dairy and convenience food packaging equipment, covering requirements that go from dosing to wrapping. A specialist for marketing-oriented technical solutions, Corazza is also renowned for prompt and reliable customer service. The machine portfolio also comprises secondary and end-of-line packaging solutions.

Today Corazza manufactures complete packaging lines for fresh, processed & cream cheese, butter, yeast, paste & pressed soup cube.

[ima.it/foodanddairy](https://ima.it/foodanddairy)



**Benhil GmbH • IMA Corazza Division**  
dairyfood@ima.it • [ima.it/foodanddairy/about](https://ima.it/foodanddairy/about) • [ima.it](https://ima.it)  
FOLLOW IMA 