



# Macadams 120

## Rotary Rack Oven With SMART Controller

Fitted with  
SMART Controller



### FEATURES & BENEFITS

- SMART Controller Technology with intuitive controls.
- Easy maintenance.
- Canopy optional.
- Hook or platform system with ramp (optional).
- Electrical or fuel execution.
- High grade stainless steel design = Robust design.
- Auto Damper & Auto Extractor.
- Effective steam technology.



M120 ROTARY RACK OVEN	
<b>Power Rating (kW)</b>	Electrical : 46 kW Fuel : 76 kW (burner) + 1.3 kW Electrical
<b>Supply Voltage</b>	400 V, 50 Hz 3 phase, neutral & earth. Other voltages available on request.
<b>Control Voltage (V)</b>	230 V / 24 DC
<b>Current Rating at 400 (A)</b>	Electrical : 70 A Fuel : 2 A
<b>Baking Surface (m<sup>2</sup>)</b>	8.7 m <sup>2</sup>
<b>Product:</b> Standard Bread: 600 - 900 g Rolls: 60 g (6 x 5 / tray) Baguettes: 500 g (6 fluted trays) Pies (foil): 100 g (6 x 5 / tray)	<b>Capacity</b> 120 loaves per bake 45 dozen per bake 108 per bake 45 dozen per bake
<b>Capacity</b>	18 x (600 x 800) mm
<b>Weight (kg)</b>	Electrical : 1120 kg Fuel : 1155 kg

\*Oven dimensions in mm: Excludes all protrusions (door handles, drain exits etc). Allow an additional 200mm for protrusions.

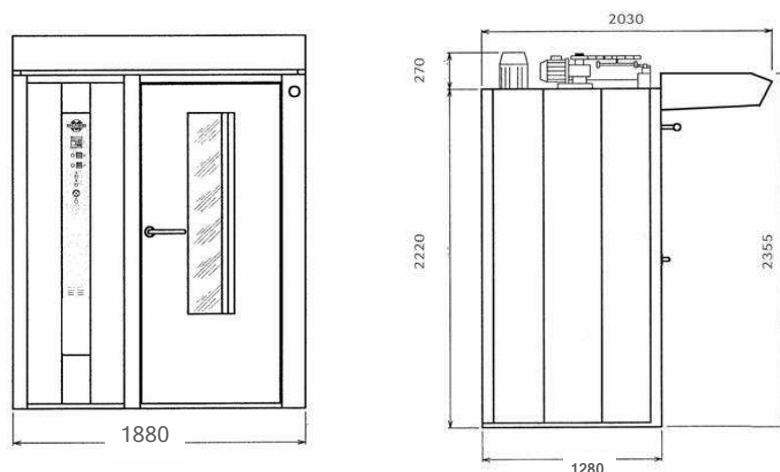

## Contact Details

HEAD OFFICE, EXPORTS & CAPE TOWN BRANCH Tel : +27 (21) 907-1000 Fax : +27 (21) 907-1111

JOHANNESBURG BRANCH Tel : (011) 472-4100 Fax : 086 618 6462

DURBAN BRANCH Tel : (031) 569-6290 Fax : (031) 569-6296

EMAIL [info@macadams.co.za](mailto:info@macadams.co.za)

WEBSITE [www.macadams.co.za](http://www.macadams.co.za)